



This product, formerly sold by ams AG, and before that optionally by either Applied Sensors GmbH, acam-messelectronic GmbH or Cambridge CMOS Sensors, is now owned and sold by

SciSense

The technical content of this document under ams / Applied Sensors / acam-messelectronic / Cambridge CMOS Sensors is still valid.

Contact information

Headquarters:

Sciosense B.V.

High Tech Campus 10

5656 AE Eindhoven

The Netherlands

info@sciosense.com

www.sciosense.com



Application Note

AN000546

Safe Power on Energy Harvesting

Ideal switching on and off

v0-01 • 2018-Apr-23

Content Guide

1	Introduction.....	3	5	Revision Information.....	8
1.1	Ordering Information	3	6	Legal Information	9
2	PICOSTRAIN	4			
3	PICOCAP	6			
4	Summary / Results	7			

1 Introduction



Information

This application note only needs to be taken into account when using:

- harvesting mode
- alternating operation of power supply (switching off and on)

PS081, a resistance-to-digital converter (RDC), is a system-on-chip for ultra-low power and high resolution applications. It was designed especially for weight scales but fits also to any kind of force or torque measurements based on metal strain gages. It takes full advantage of the digital measuring principle of ams PICO STRAIN.

PCap04 is a capacitance-to-digital converter (CDC) with integrated digital signal processor (DSP) for on-chip data post-processing. Its front end is based on ams PICO CAP principle.

For a good measurement quality it is mandatory to follow some rules for the power supply, which are written in the data sheets of the converters.



Attention

In order to avoid malfunctions when switching back on, a safe shutdown must be ensured.

Turning on the converters earlier, as long as the supply voltage is greater than zero, may cause malfunction.

Especially the specified power-down for these converters is to drive the supply voltage down to zero.

1.1 Ordering Information

Ordering Code	Description
PS081	Resistive Sensing
PCap04	Capacitive Sensing

2 PICOSTRAIN

For example solar applications without any additional battery it is necessary to implement a power-up circuit. It provides a good start-up behavior when the scale comes from total darkness. A solar panel delivers only a few microampere at poor light conditions and still has to start up the circuit.

Figure 1 shows a power-up circuit that is optimized for kitchen scales using PS081. To start up the scale it needs only about 3 μA @ 3.6 V. For other applications it might be necessary to change some values of the components.

Figure 1:
Power-up Circuit

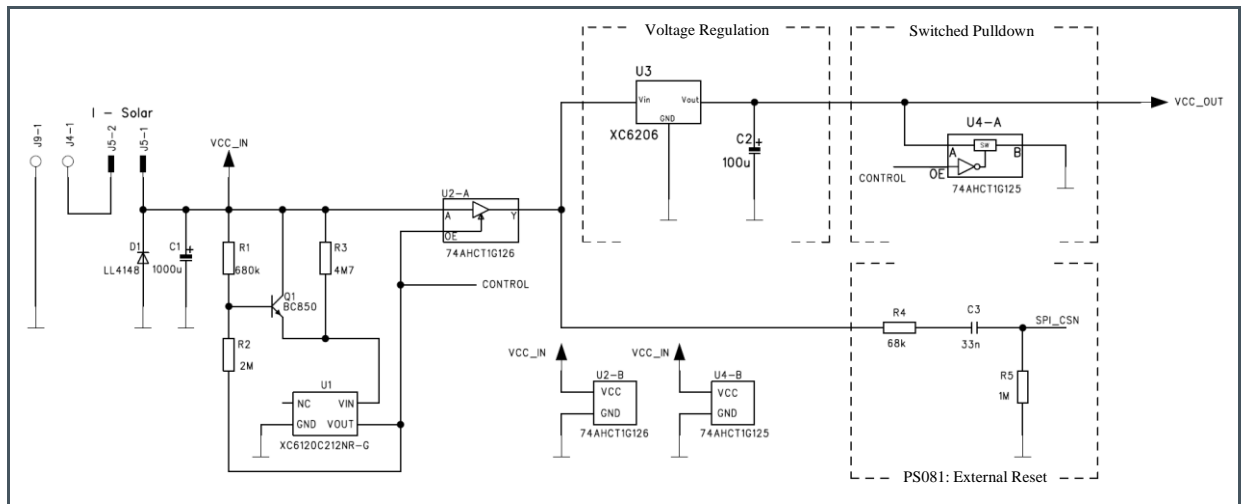

Figure 2:
Compressed Bill of Materials list

Reference	Type
Q1	NPN general purpose transistor
U1	Low Power Voltage Detector
U2	Single Buffer Gate with 3-state Output
U3	Low ESR Cap. Compatible Positive Voltage Regulator
U4	Bus buffer/line driver; 3-state with inverted output enable (OE)

Short description of the function:

Coming from total darkness, all capacitors are discharged and the output of U2 is high-Z. The input voltage of U1 is zero. The converter is not supplied by voltage. If light is switched on, the current from the solar panel charges C1 and supplies the voltage detection. The voltage detection (R7, R14, Q1, U1) is dimensioned so that U1 switches when the voltage at C17 passes 3.5 V. At that moment, the output of U2 leaves high-Z and goes to the voltage of C17.

U3 is supplied with 3.5 V and regulates to 2.5 V for the converter and it begins to work. Because all capacitors behind U2 have now to be charged to the voltage at C17, this voltage drops down as only C17 can supply the necessary current. C2 should be 5 to 10 times smaller than C17.

The solar panel is too weak for such a high current pulse. The voltage at C17 must not be lower than 2.55 V. Otherwise U3 cannot regulate 2.5 V for the converter. C17 is also the buffer capacitor for low light situation. With the selected dimension under very bad light condition (e.g. 20 Lux) the scale can operate for minimum 1 minute if it is well charged before. Therefore 1000 μF is the recommended value for C17 (minimum 680 μF).

Avoid to go below 680 μF . The circuit cannot start up if C17 is too low. The circuit will work with higher values, too, but the start-up time from darkness will increase because the charging time for C17 increases. The circuit is evaluated in detail and it is strongly recommended to follow the recommended values for a correct operation.

For PS081, external power on reset is possible in stand-alone mode by an external power-on at pin 27 (SPI_CSN_RST). This simple watchdog function is realized by R4, C3 and R5.

When supply voltage is reduced, the output of U2 is high-Z and the U4 switches VCC_OUT to GND. It makes sure VCC_OUT is reduced to true 0V and not only to a level $< 0.8\text{V}$.



Attention

To avoid any malfunction, the exemplary circuit is only be used as a template and must be verified and evaluated by the customer in any case.

3 PICOCAP

A good example of use is an application with NFC communication, where the whole circuit is powered by the NFC field only. A NFC tag combined with harvesting mode feature delivers up to several mA. As soon as an NFC field is applied, the system is powered up, the customized PCap04 makes a measurement and sends the result to the NFC tag which will be read by a mobile device.

Against our recommendation and importance of sufficient buffering for the supply voltage (10 μF for VDD33 and 4.7 μF for VDD18) this NFC application uses lower buffer capacitances and additional resistance in parallel to speed up power down.

Figure 3 shows another example, a modified circuit using the analog outputs of PCap04 with pulsed power supply (e.g. frequently switched battery on/off). The power supply (e.g. battery) is not shown, only the changed buffer capacitances (in blue brackets). PCap04 is buffered with 100 pF for VDD33, 100 pF for VDD18 and at VDD18 a 22 kOhm resistor in parallel to speed up power down.

Figure 3:
Modified Schematics with I²C Interface and PDM Analog Outputs

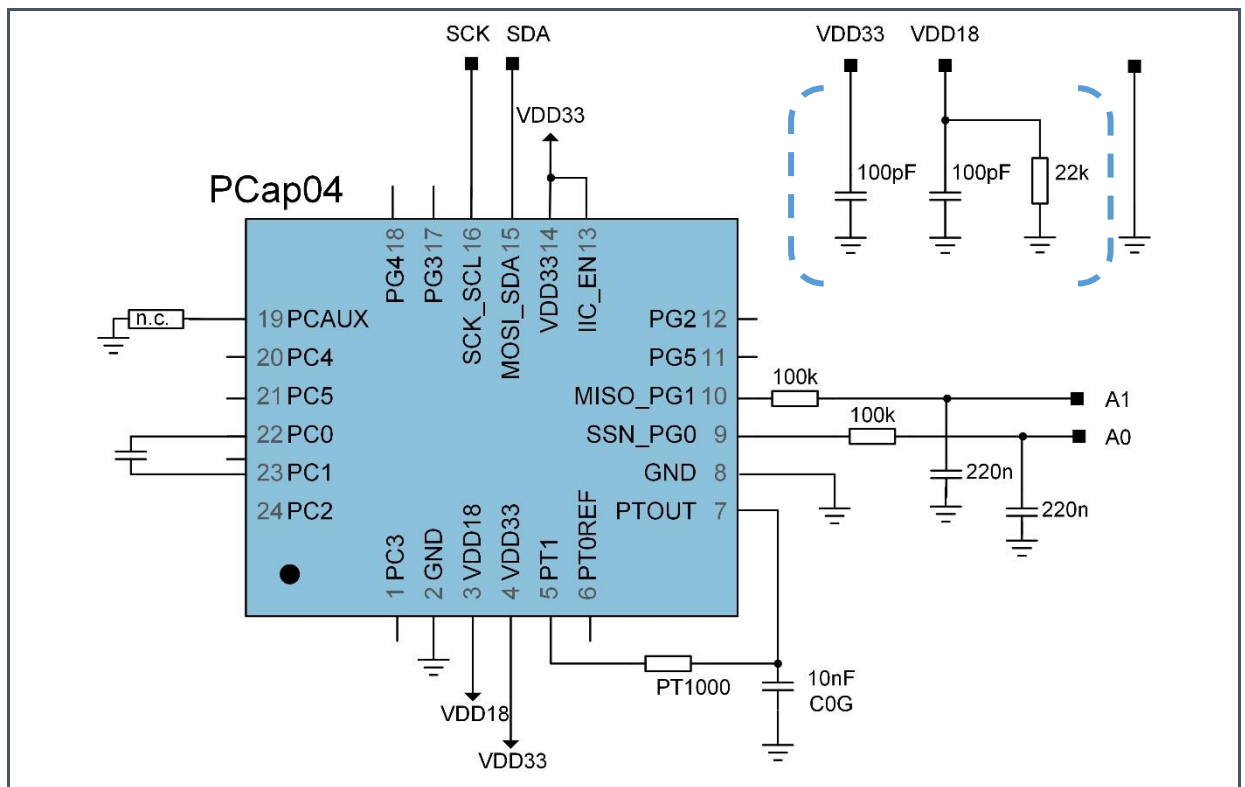

4 Summary / Results

In most circuits the voltage is regulated by a voltage regulator (LDO, low drop-out regulator). Of course this component has a noise which basically influences the measurement quality. Therefore it is crucial to choose suitable LDOs with a low-noise behavior, still keeping in mind that some applications need a low-current regulator as well.

At the end, the goal is to reach zero volt before the power supply is switched on.

Figure 4:
Differences or advantages between PICOSTRAIN / PICOCAP method

Arguments	PICOSTRAIN method	PICOCAP method
Load for the power supply / battery	Depends on configuration, several μA	Table text left aligned
Number of components, available space on PCB	10 to 15 components	No additional components, only the values have to be adjusted
Required resolution of the measurement system	Depends on configuration, maximum available resolution	Due to the low buffer capacitances and selected resistance in parallel, the resolution is lower
Switching speed of the supply voltage	Due to the high capacitances, this method is slow	Depends on the selected buffer capacitances and resistor in parallel, very fast

5 Revision Information

Changes from previous version to current revision v0-01	Page

- Page and figure numbers for the previous version may differ from page and figure numbers in the current revision.
- Correction of typographical errors is not explicitly mentioned.

6 Legal Information

Copyrights & Disclaimer

Copyright ams AG, Tobelbader Strasse 30, 8141 Premstaetten, Austria-Europe. Trademarks Registered. All rights reserved. The material herein may not be reproduced, adapted, merged, translated, stored, or used without the prior written consent of the copyright owner.

Information in this document is believed to be accurate and reliable. However, ams AG does not give any representations or warranties, expressed or implied, as to the accuracy or completeness of such information and shall have no liability for the consequences of use of such information.

Applications that are described herein are for illustrative purposes only. ams AG makes no representation or warranty that such applications will be appropriate for the specified use without further testing or modification. ams AG takes no responsibility for the design, operation and testing of the applications and end-products as well as assistance with the applications or end-product designs when using ams AG products. ams AG is not liable for the suitability and fit of ams AG products in applications and end-products planned.

ams AG shall not be liable to recipient or any third party for any damages, including but not limited to personal injury, property damage, loss of profits, loss of use, interruption of business or indirect, special, incidental or consequential damages, of any kind, in connection with or arising out of the furnishing, performance or use of the technical data or applications described herein. No obligation or liability to recipient or any third party shall arise or flow out of ams AG rendering of technical or other services.

ams AG reserves the right to change information in this document at any time and without notice.

RoHS Compliant & ams Green Statement

RoHS Compliant: The term RoHS compliant means that ams AG products fully comply with current RoHS directives. Our semiconductor products do not contain any chemicals for all 6 substance categories, including the requirement that lead not exceed 0.1% by weight in homogeneous materials. Where designed to be soldered at high temperatures, RoHS compliant products are suitable for use in specified lead-free processes.

ams Green (RoHS compliant and no Sb/Br): ams Green defines that in addition to RoHS compliance, our products are free of Bromine (Br) and Antimony (Sb) based flame retardants (Br or Sb do not exceed 0.1% by weight in homogeneous material).

Important Information: The information provided in this statement represents ams AG knowledge and belief as of the date that it is provided. ams AG bases its knowledge and belief on information provided by third parties, and makes no representation or warranty as to the accuracy of such information. Efforts are underway to better integrate information from third parties. ams AG has taken and continues to take reasonable steps to provide representative and accurate information but may not have conducted destructive testing or chemical analysis on incoming materials and chemicals. ams AG and ams AG suppliers consider certain information to be proprietary, and thus CAS numbers and other limited information may not be available for release.

Headquarters

ams AG
Tobelbader Strasse 30
8141 Premstaetten
Austria, Europe
Tel: +43 (0) 3136 500 0

Please visit our website at www.ams.com

Buy our products or get free samples online at www.ams.com/ICdirect

Technical Support is available at www.ams.com/Technical-Support

Provide feedback about this document at www.ams.com/Document-Feedback

For sales offices, distributors and representatives go to www.ams.com/contact

For further information and requests, e-mail us at ams_sales@ams.com