



This product, formerly sold by ams AG, and before that optionally by either Applied Sensors GmbH, acam-messelectronic GmbH or Cambridge CMOS Sensors, is now owned and sold by

SciSense

The technical content of this document under ams / Applied Sensors / acam-messelectronic / Cambridge CMOS Sensors is still valid.

Contact information

Headquarters:

Sciosense B.V.

High Tech Campus 10

5656 AE Eindhoven

The Netherlands

info@sciosense.com

www.sciosense.com



acam-messelectronic gmbH

is now

Member of the ams Group

The technical content of this acam-messelectronic document is still valid.

Contact information:

Headquarters:

ams AG

Tobelbaderstrasse 30

8141 Unterpremstaetten, Austria

Tel: +43 (0) 3136 500 0

e-Mail: ams_sales@ams.com

Please visit our website at www.ams.com

PICOSTRAIN

Application Note

Design Guidelines for Building a Solar Body Scale Revised Power-Up Circuit

17. September 2009
Document-No.: AN003_e V1.3



1	Foreword - What has Changed ?	1
2	Supply Current.....	1
2.1	Power-up Circuit	2
2.2	Comparison of Results PSO8 vs. PSO81 circuit.....	3
3	Remarks to the new schematic	6
4	PCB Layout considerations	9
4.1	Important Components	9
5	Parameter setting of the Software	12
5.1	Important parameters	12
5.2	Program Structure (Flowchart)	14
6	Appendix	15
6.1	Schematics.....	15
6.2	PCB Layout.....	17

1 Foreword - What has Changed ?

In 2008 acam built up a solar body scale with PSO8 for demonstration and evaluation. This was the first real solar driven scale that uses strain gages as sensors. The circuitry was optimized to PSO8 and according to the knowledge we had about the edge conditions of body scales, e.g. lighting conditions, size of solar panel, etc. Today, in July 2009, we have the PSO81, the revised version of PSO8.

With the new circuitry of the solar body scale using PSO81 we are addressing requests for a quicker start-up behavior of the whole scale and to make the scale run at very bad lighting conditions. More than that, the circuitry was optimized to a smaller bill of material (BOM) in order to have minimum costs.

The improvements of this revision are significant. Especially the startup current was lowered by more than a factor of two and the start-up time from darkness is improved by the factor of 3 to 5 under the same lighting conditions. In this paper we point out the differences between the two circuits, the performance of the revised circuitry and how to consider these changes in your design.

Please stick close to our recommendations when doing the changes in your hard and software. The circuitry was optimized to a maximum and works well when built up as recommended. Even small changes can lead to malfunction of the whole scale!

2 Supply Current

The solar body scale as demonstration system was revised due to the introduction of PSO81. Some of the mayor changes are:

- Use of PSO81
- Reduction of current consumption from 17 μA to 12 μA in measurement mode
- Reduction of the power up current from 8 μA to 3 μA
- Reduction of Auto-On scan current from 6 μA to 3.5 μA
- Revised power-up circuit to improve start-up behavior of the scale
- Reduction of components and total bill of material (BOM)

The following two paragraphs describe the main differences between the former and today's power up circuit, followed by some charts comparing the performance of both.

2.1 Power-up Circuit

The former power up circuit of PSO8 version works well with a secure start-up behaviour. The only disadvantage of this circuit was a start-up current of minimum 8 μ A. The circuit does not start if the solar pannel does not deliver a minimum of 8 μ A @ 3.3 V. This fact lead to a minimum start-up light of 55 Lux with a 50 μ A @ 200 Lux solar panel – too much for a dark bathroom.

The revised power up circuit is now optimized for lowest start-up current and fastest possible start-up behaviour. Therefore, the current consumption of the circuit itself is lowered. By implementing Q1 and R10, the new minimum start-up current is 3 μ A. This reduces the minimum light significantly by more than the half.

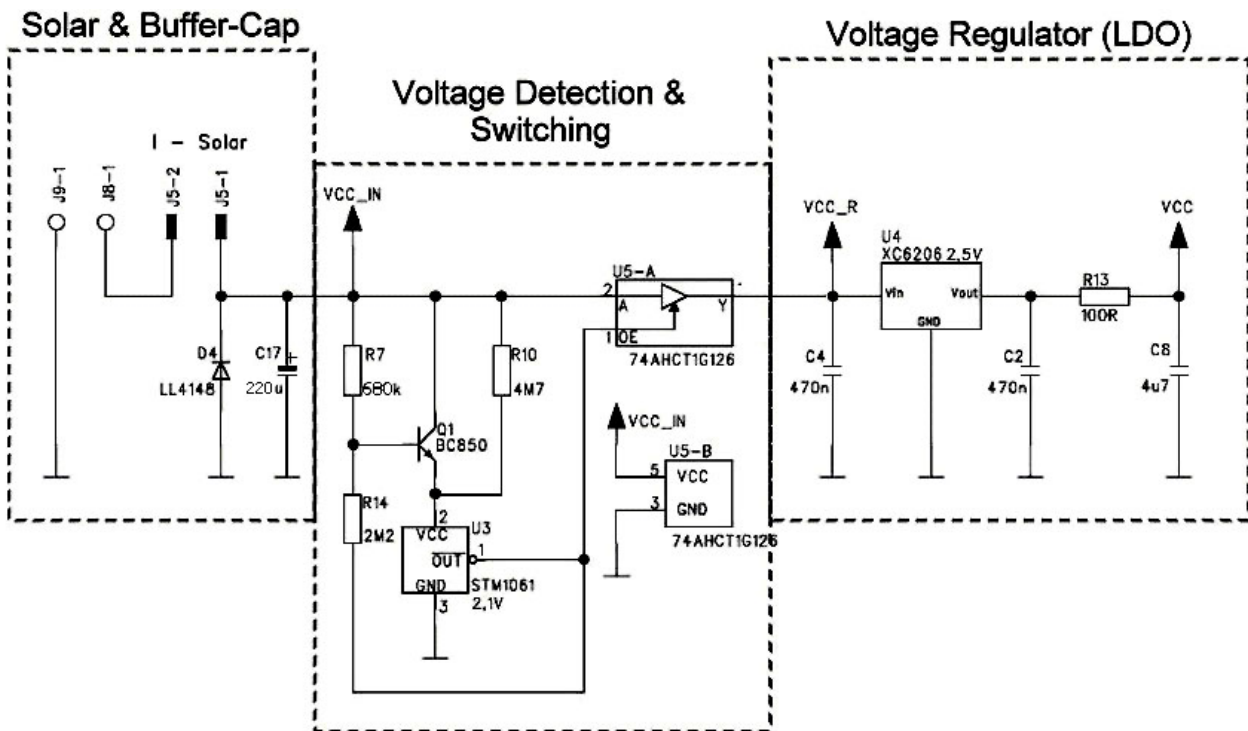

Figure 1: Power-up circuit

Short description of the function:

Coming from totally darkness, all capacitors are discharged and the output of U5 is high-Z. The input voltage of U4 is zero. PSO81 is not supplied by voltage.

If light is switched on, the current from the solar pannel charges C17 and supplies the voltage detection. The voltage detection (R7,R14,Q1,U3) is dimensioned so that U3 switches when the voltage at

C17 passes 3.5 V. At that moment, the output of U5 leaves high-Z and goes to the voltage of C17. U4 is supplied with 3.5 V and regulates to 2.5 V for the PS081. PS081 begins to work. Because all capacitors behind VCC_R have now to be charged to the voltage at C17, this voltage drops down as only C17 can supply the necessary current. The solar panel is too weak for such a high current pulse. The voltage at C17 must not be lower than 2.55 V. Otherwise U4 cannot regulate 2.5 V for the PS081. C17 has to be dimensioned carefully to make sure that 2.5 V are not undershot. Therefore, 220 μF is the recommended value for C17 (minimum 150 μF). At lower capacitance the circuit cannot start up. The circuit will also work with higher values, but the start-up time from darkness will increase because the charging time for C17 increases.

With this circuit it is possible to have a very quick start-up behavior and a safe start-up even at very dark light conditions.

The replacement of the FSA66 switch by a standard 74AHCT126 lowers costs.

2.2 Comparison of Results PS08 vs. PS081 circuit

In general, the start-up time of the scale is influenced by the following parameters:

- Size / current of the solar panel
- Current consumption of the power-up circuit
- Lighting conditions

If we compare these parameters between the former and new circuit, we can see the following differences:

- The current out of the solar panel for starting the scale should be minimum 8 μA for the PS08 circuit and 3 μA for the new PS081 circuit. The current consumption of the power-up circuit was reduced by nearly 2/3.
- Also at bad lighting conditions, such as <25 Lux, the PS081 circuit will start up.

The following diagram (Figure 2) shows a comparison between the start-up behavior of the old vs. new circuit:

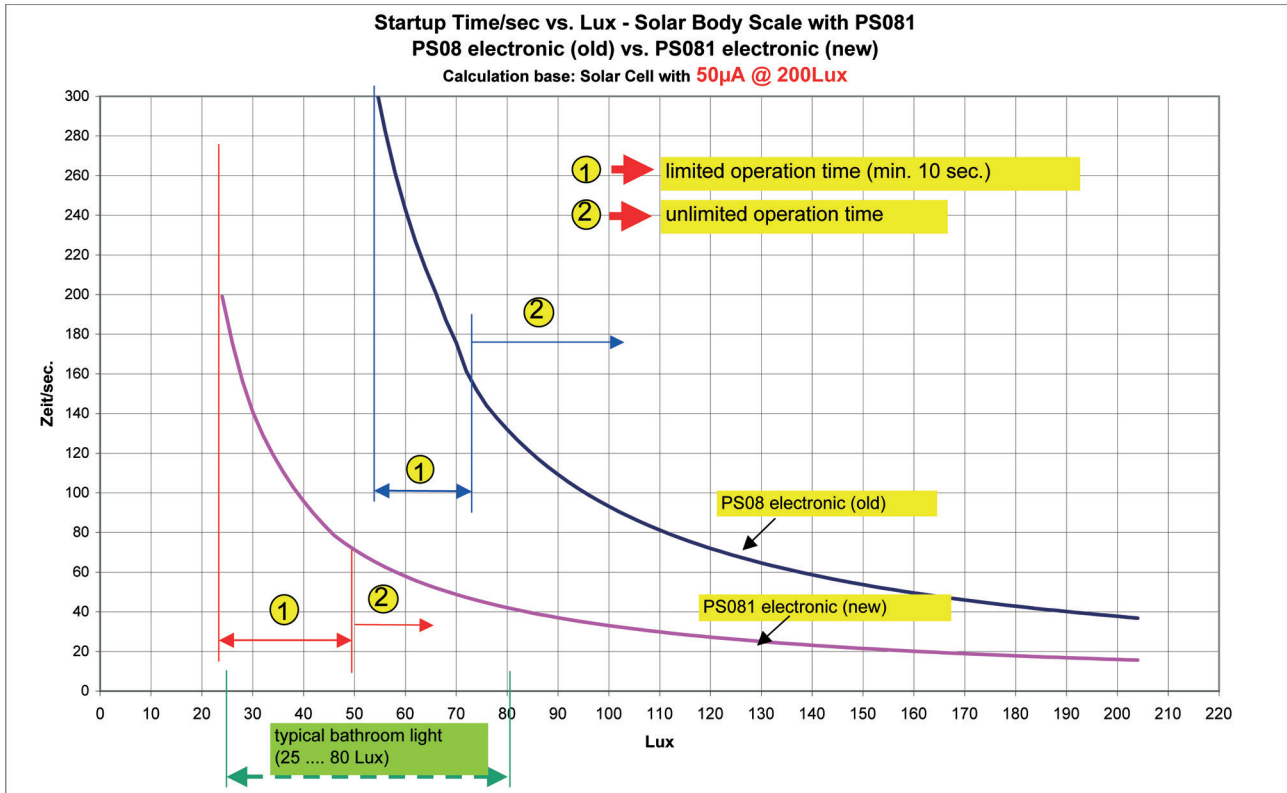

Figure 2

The blue curve is showing the start-up behaviour of the former circuit and the pink curve of the today's circuit. Depending on the light to which the scale is exposed, the start-up time varies (y-axis). It can be seen, that the minimum light needed for the former circuit was in the range of 55 Lux to start up at all. This is significantly reduced with the new circuit to approx. 25 Lux. Range 1 is the area where the current in operation is too high for permanent measuring and therefore only a limited measurement time is possible (min. 10sec.). In range 2 the current coming from the solar cells covers the need for the measurement and therefore 'unlimited' operation is possible. The solar panel delivers 50 µA at 200Lux.

The next diagram, figure 3, is showing more detailed information about the start-up behaviour of the new circuit.

The green curve shows the time needed to come up for first internal measurements, depending on the lighting conditions. These first measurements are used for determining the offset. They are not equal to a final result which could be given to the user. Nevertheless, some scales might have a 'start-up message', like a blinking LCD sign that indicates to the user that the scale is powered up. It takes at least 6 s to determine the offset and to switch to measurement. The pink curve shows the time needed for the scale to be ready for measurements, depending on the lighting conditions.

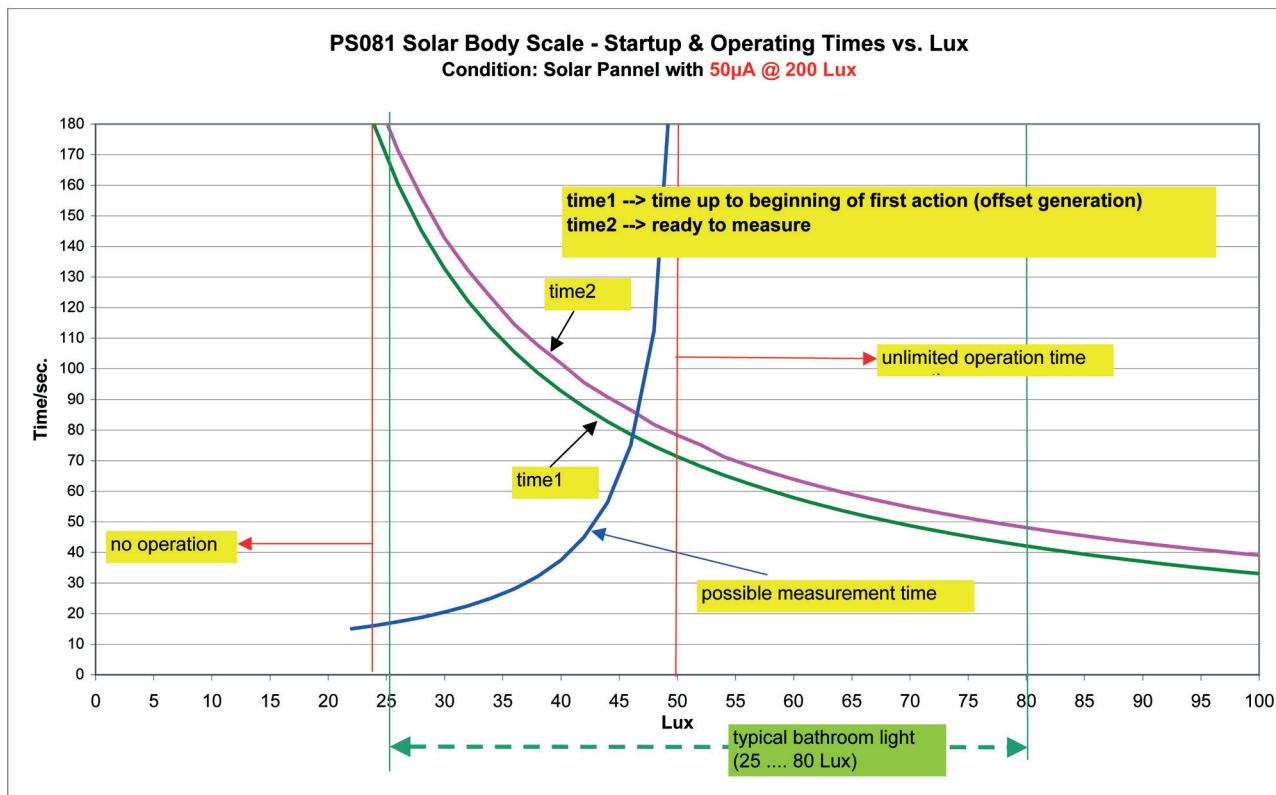

Figure 3

The blue curve shows the possible duration of measurements in seconds. At poor lighting conditions, this will be only about 10 seconds and only 1 measurement can be done until the scale switches off. This time increases significantly with brighter light. From 60 Lux upwards 'unlimited' operation is possible.

The next graph, figure 4 on the following page, shows the start-up behaviour of the new circuit again, this time based on a solar panel delivering 100 µA at 200 Lux.

The curves are the same as described in the diagram before. Nevertheless, it can be seen that start-up behaviour is **significantly quicker with a bigger solar panel**. Longer measurement time can be achieved with very weak light. With this type of solar panel, the scale will work down to 15 Lux, which is really bad lighting conditions.

In conclusion, the PS081 based electronic shows a significantly better start-up behaviour of the scale. Even at poor light conditions (at e.g. 20 Lux) a fast start-up is possible, though lasting from some 10 seconds to minutes. We recommend to use the new circuitry in combination with PS081 to ensure best possible start-up behaviour.

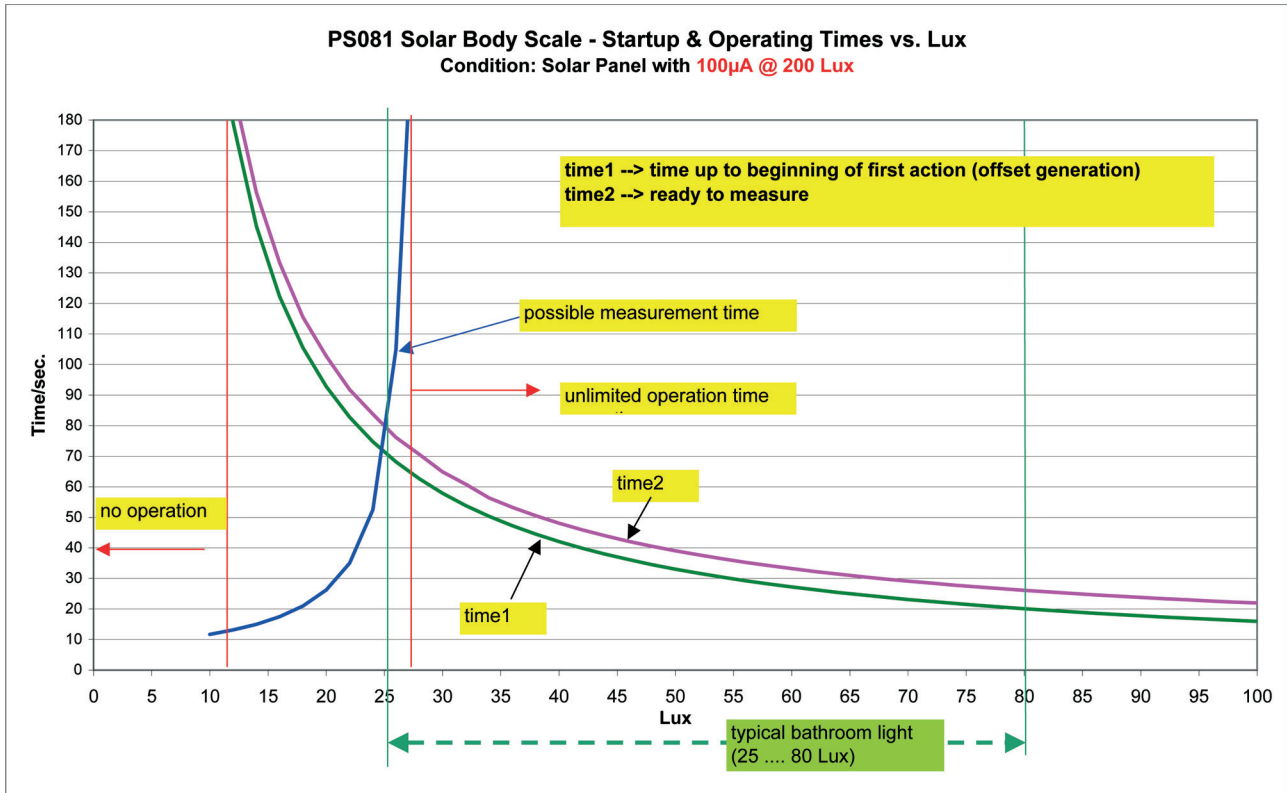

Figure 4

3 Remarks to the new schematic

This section describes some of the most important components of the new schematics that we provide with this paper. The red, underlined components are critical. Please follow strictly our recommendations for these components. Otherwise a malfunction of the device can occur.

Any component not described herein is less critical or only part of our evaluation PCB and not needed for customers' scales.

Solar Panel

Not part of the schematic. The solar panel has to supply the right voltage. It has to deliver a voltage of $> 3.6\text{ V}$ at $3\ \mu\text{A}$ under the minimum required lighting conditions, otherwise the circuit will not start.

We use solar panels from Sinonar, which are amorphous silicon panels with 8 stripes, that fulfil this requirement.

C17

Function: Capacitor to charge the current of the solar panel

Type: Tantalum or Aluminum electrolytic capacitor

Value: $\geq 220 \mu\text{F} / 6.3 \text{ V}$

Remark: No additional requirements, any standard capacitor with this value can be used. Do not go below $150 \mu\text{F}$ otherwise malfunction can occur.

R7, R14, R10,

Q1, U3, U5

Function : Startup circuit from darkness. Functionality described above.

Remarks to the components

R7, R14, R10

Normal resistors. **Please use recommended values.**

Q1

Normal NPN transistor, No special requirements.

U3

Function: Power-up detection circuit with Open Drain output

Remarks: A 2.0 V or 2.1 V Type should be used. We have chosen STM1061 because of its low current consumption of $1 \mu\text{A}$ typical. The current of this part has to be supplied all the time from the solar panel. Any other type with the same functionality can be used, but a higher current has to be taken into the calculation of lighting conditions.

U5

Single Gate 74ACT126 Tri-state Buffer. No special requirements, use available standard types.

U4

Function: Ultra-low quiescent current low-drop linear regulator. The low quiescent current and the low drop are important because they have an impact on the performance. The quiescent current has to be fully factored into the current needed by the scale in all modes. The used XC6206 has a quiescent current of only $1 \mu\text{A}$.

A 2.5 V type has to be used. Otherwise, the dimensions of many other components are wrong and a malfunction can occur.

R8, R11, C18

Function: Generate a safe power-on reset to the PSO81 when the supply voltage of the PSO81 is switched on.

No special requirements on the components. Please use recommended values.

C1

Function: Load capacitor for the measurement

Type: COG

Value: 47 nF

Remarks: Very important capacitor. One of the parts that are mainly responsible for the measurement quality. Please use a COG type ceramic capacitor. Other materials (e.g. CFCap) may be also possible, but we have not tested them.

Do not use X7R types. The noise will increase and the stability of the result will decrease.

C14

Function: Blocking capacitor for Vcc Load.

Type: Tantalum or Aluminum electrolytic capacitor

Value: 10 μ F

Remark: Use exactly 10 μ F, do not use a lower value. If a higher value is used then C17 also has to be increased, otherwise a malfunction can occur. For details ask acam.

C7, C16

Function: Blocking capacitors for Vcc-Core

Type: no special requirements

Value: 4.7 μ F

Remark: Place C7 close to pin 26 of PSO81 and C16 close to pin 2 of PSO81

C5

Function: Blocking capacitor for the comparator

Type: no special requirements

Value: 2.2 μ F

Remark: Place C5 close to pin 32 of PSO81

C6, R6

Function: low pass filter for the comparator, no special requirements on the components. Please

choose recommended values.

Remark: Place close to Pin 31, Pin 34 of PS081

R4, R5

Function: resistors for temperature measurement and gain compensation

Type: R4 → 1kOhm metall film resistor

R5 → 1kOhm carbon resistor

Remarks: R4 & R5 have to be in the same range as the strain gage resistors (normally 1 kOhm). With R4 and R5 the gain compensation of the uncompensated halfbridges can be done using the RSPAN_BY_TEMP options. For more information please refer to the PS081 manual or our application note regarding this item.

R12

Function: enable a fast oscillator shutdown, to save current

Value: 1MOhm

No special requirements on the components. Please use recommended values. Simple but important component for low current consumption.

4 PCB Layout considerations

Prefix: Three elements are necessary to build a satisfying solar scale:

- PICOSTRAIN
- The right parameter settings
- A good layout

A good (double layer) layout is important to get the measurement quality required. Demands are focused only on a few components and only to a part of the PCB. But don't underestimate their importance. Here we give the needed information for every critical component and also some general information on the layout.

4.1 Important Components

Following 12 components have to be placed and routed on the PCB under special restriction

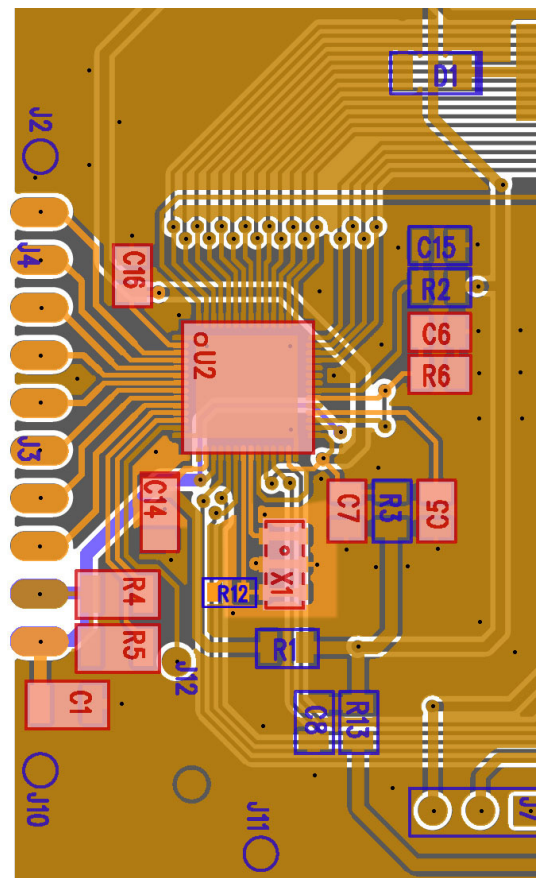

Figure 5

- PSO81
- R4,R5
- X1
- C7, C16
- C14
- C1
- C5
- C6, R6
- R12

Figure 5 shows a good placement of the critical components. The center of this layout section is of course the PSO81. The critical parts have to be placed around this components.

PSO81 itself has to be placed on the edge of the PCB where the strain gage connections (J3,J4) are placed. Place the strain gage connections at one edge of the PCB and not in the middle. No other line should cross the strain gage lines between the connection and the PSO81.

R4, R5: Gain Compensation and temperature measurement resistors. Therefore, part of the strain gage measurement. Not very critical, place them close to Pins 11,12 of PSO81.

X1: Critical to place, must not be disturbed and may not disturb. Place as close as possible to Pins 20 & 21 of PSO81. Flood as good as possible a ground plane around the component on both sides of the PCB. Especially the load line must not cross this component.

C7, C16: Not very critical, but place them as good as possible, C7 close to Pin 27 (Vcc-HA) and C16 close to Pin 2 (Vcc-Core).

C14: Critical to place. Place it close to pin 16 (Vcc-Load). A good ground plane between C1 and C14 is needed.

C1: Critical to place. Place it close to the Load ports of the PCB. A good ground plane between C1 and C14 is needed.

C5: Not very critical. Place it close to pin 32 (UCOMP1) of PSO81.

C6,R6: Not very critical. Place it close to Pin 31,34 of PSO81

R12: Critical to place. Place as close as possible to X1

Additional hints:

Load Line: The load line which connects all strain gage resistors and also C1, Pin17 (Load) and Pin30 (Sense_In) is very critical. Special care has to be taken about this line.

- do not cross X1 with this line on any layer
- do not cross the SG Ports (Pin3 ... Pin11) of the PSO81 with this line
- make as good as possible a ground plane around this line on both layers

Ground Plane: A good ground plane is very important for good measurement results. Because of commercial reasons only a double layer can be used, it is very important to do the best for a good grounding of the critical components.

Our recommendations are:

- flood with ground the empty space on **both** sides of the PCB.

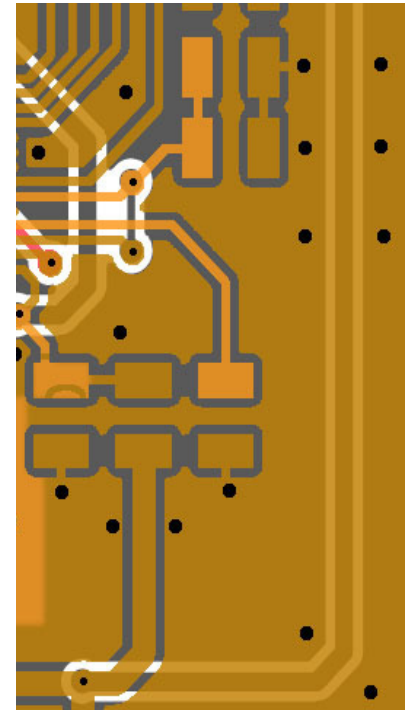

Figure 6

- Connect both ground planes with vias (black spots in the figure 6) on several locations on the PCB.
- If a longer line (e.g. Load Line) “cut” the ground into 2 stripes, “shortcut” these ground stripes on the other layer, again by vias.

If these hints are followed the possible measurement results of such a double layer PCB is very close to those of a multilayer PCB and good enough for a solar driven scale which has, because of its highly pulsed operation, high requirements on a good layout.

5 Parameter setting of the Software

5.1 Important parameters

Our PICOSTRAIN devices can be used in many different applications like

Solar driven scales down to 12 uA total operating current

High resolution scales up to 250.000 scale divisions

Legal for trade scales up to 10.000 Div. OIML

Therefore, all our PICOSTRAIN chips have several parameter registers, where the device has to be set in the proper operating condition for the special application.

We provide with this paper also a application software. It sets all these registers to the right value for this application. Nevertheless, we want to give here a list of register settings which are very critical and which have to be used according our recommendations.

The solar body scale application software is based on an auto-on scale with automatic zero tracking. In Off Mode the scale scans permanently (once per second) the strain gage sensors with low resolution (approx. 0.5 kg peak-peak). Also, the offsets of the sensors are measured frequently (once in 5 minutes) with full resolution. If in scan mode a weight is detected, the scale switches on and measures with an update rate of 2 Hz and < 0.1 kg peak-peak resolution.

Therefore we have 2 modes:

- Scan mode
- Measure mode

Both modes have important parameters which have to be set to get a proper operation. In the following table we give you the major settings for both modes. Settings that are not described can be set according customers request or default values can be used. A sample setting for all parameters can be found in our application software.

Parameter	Register	Bit	Mode		Remark
			Measure *	Scan *	
Cycle Time	2	4..13	33	33	right setting for 47nF C1
AVRate	2	14..23	2	2	
bridge	3	0..1	3	1	4xHB measurement, 1xHB scan
con_comp	11	0..1	1	1	
sel_compr	0	14..15	3	3	
sense_discharge	16	10	1	1	
single conversion	2	2	1	1	
mfake	3	2,3	0	0	
sel_start_osz	3	17..19	5	5	
stretch	3	12..13	0	0	no stretch mode
dis_osc_startup	0	3	1	1	
ps081adjust	3	4..9	16	16	important noise setting
pptemp	2	3	1	0	no compensation in scan mode
mult_en_pp	1	7	1	1	Use gain comp. and temp meas.
mult_pp	10	0..7	164	164	Recommended 1.28 (real)
dis_noise4	3	14	1	1	
lcd_directdrive	16	19	1	1	Use direct drive for LCD
tdc_conv_cnt	0	16..23	75	150	update frequency 2Hz measurement, 1Hz scan
rspan_by_temp	1	8	1	1	enable rspan_by_temp option
mod_rspan	1	6	1	1	enable mod_rspan
mult_tkg	8	0..23	0x100000	0x100000	1.0=default, dependent on used strain gage
mult_tko	9	0..23	0	0	use default

*all values decimal

red = differences between the modes

5.2 Program Structure (Flowchart)

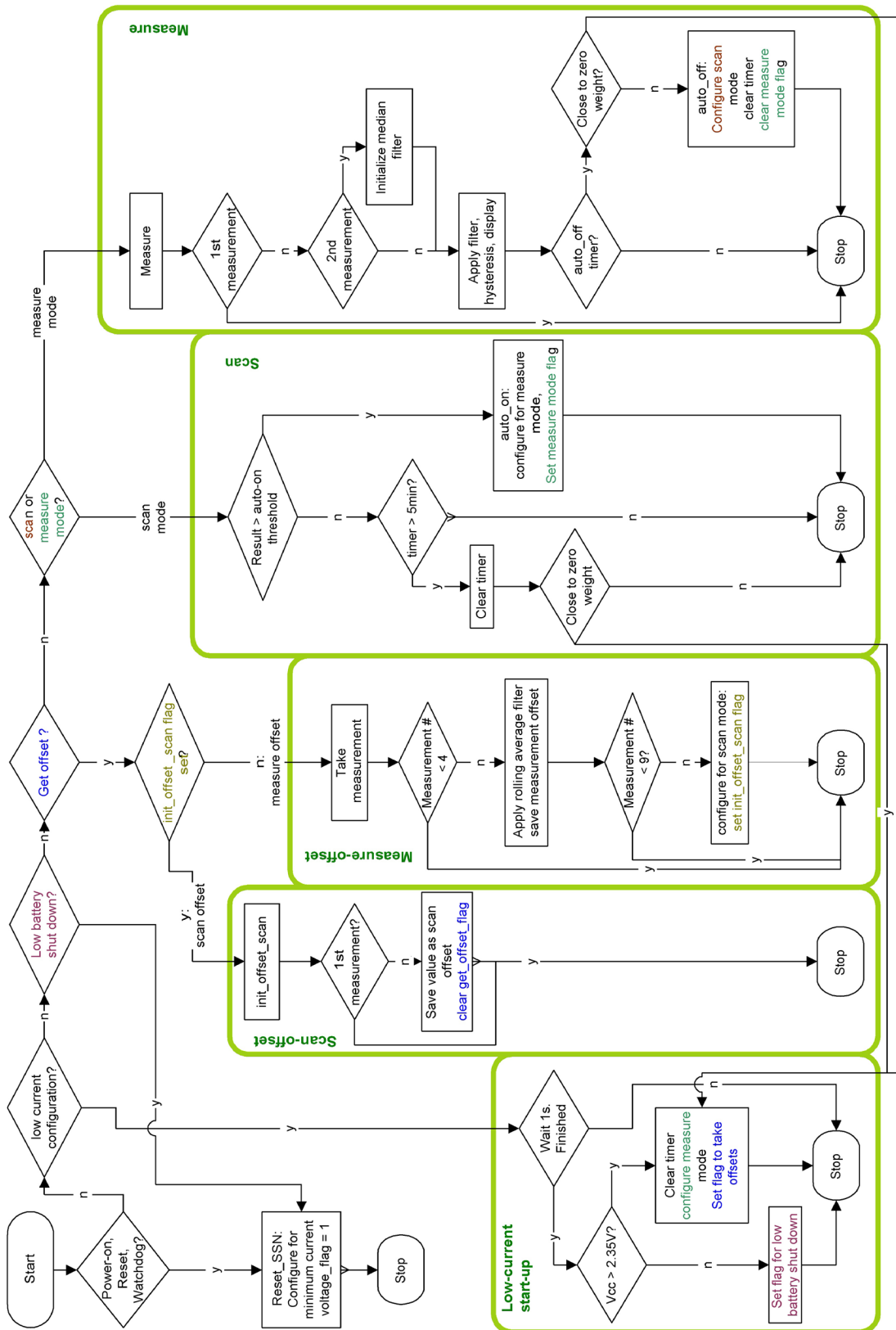

The complete assembler program can be downloaded from our website:

http://www.acam.de/fileadmin/Download/_software/Quat_solar_PSO81.asm

Description:

The program is a for a solar quattro application. The scale turns on automatically when weight is applied (weight change of min 3 kg).

Program features include:

- 5 time median average
- Zero offset
- LCD display for 5 digits
- Auto-OFF
- Auto-ON
- Scan offset in Off mode to display correct weight immediately after weight change detection

On POR configuration is set to minimum current and it is waited for 1 sec. If the voltage is o.k. after that, the measure configuration is set and the initial offset is measured. The the initial offset for scan mode is taken. After that, it is switched to scan mode and the value for auto-on is scanned. The scan offset is actualized every 5 minutes. If there is a weight change of > 3 kg, the scale is switched on. If the scale is on for some time, it is switched off automatically.

The program is an small engineering solution intended to demonstrate the start-up capability of a solar scale with PSO81. It has implemented the basic functions only. It does not cover all functions of a real scale. E.g. freezing the display is not included.

6 Appendix

6.1 Schematics

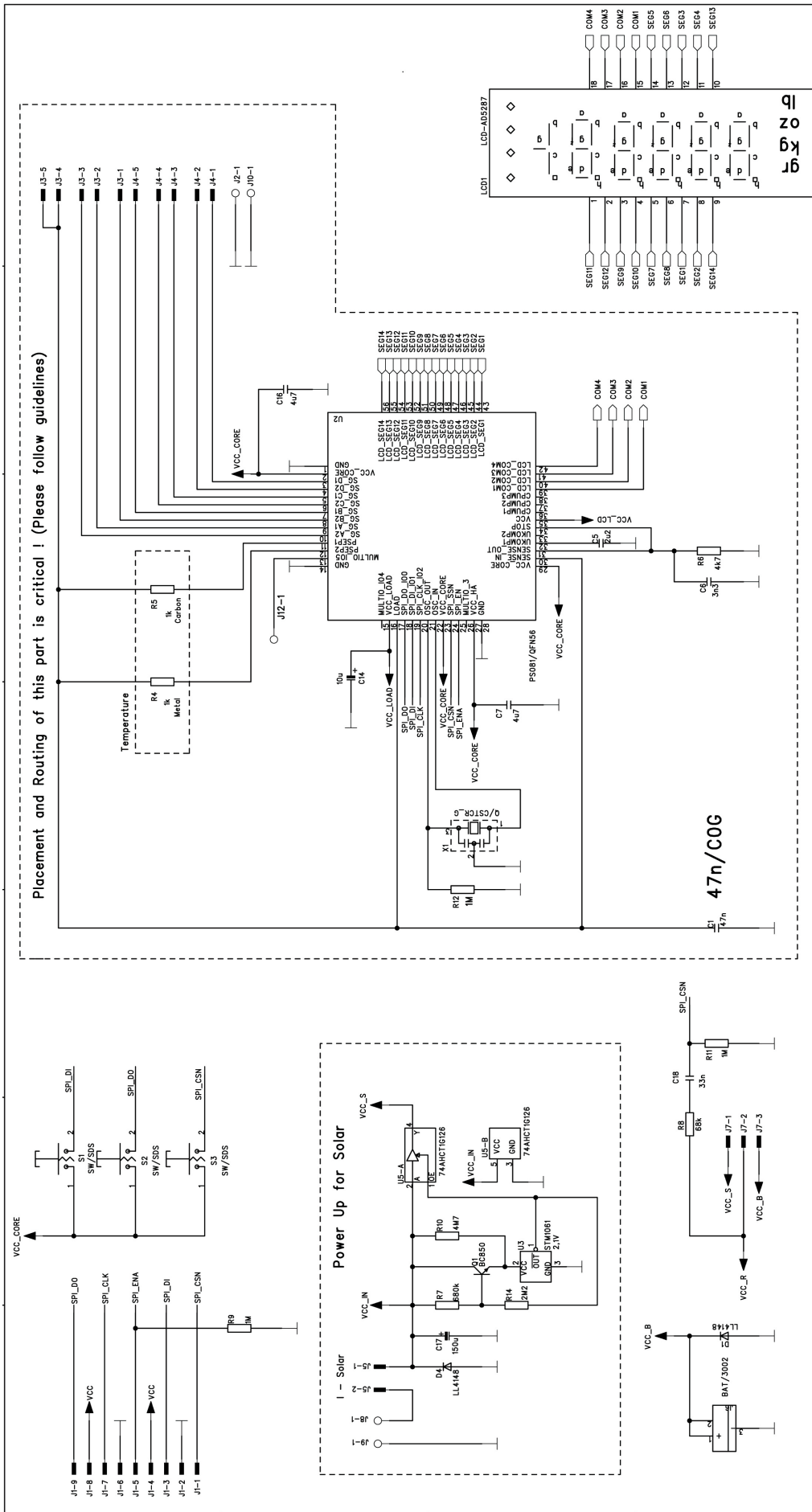

Placement and Routing of this part is critical ! (Please follow guidelines)

REVISION RECORD		COMPANY:	
LTR	ECD NO:	DATE:	
1	1.2	12.08.09	
APPROVED:		DATE:	
UTG		12.08.09	
TITLE:			
PS081 Solar Quattro			
DRAWN: Robbie Dasia 12.08.2009			
CHECKED: UTG 12.08.2009			
QUALITY CONTROL:		CODE:	REV: 1.2
RELEASED:		SIZE: A3	Drawing NO: Quattro_Solar_07.sch
		SCALE:	SHEET: 1 of 1

6.2 PCB Layout

